



PB-600

Instruction Manual

1. Front and back panel

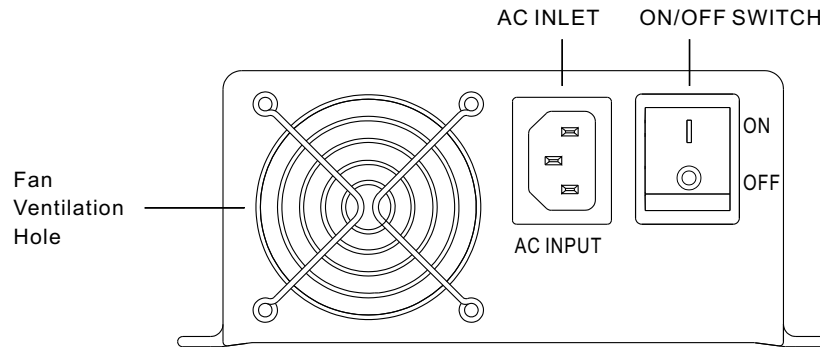

Figure 1.1 Front Panel

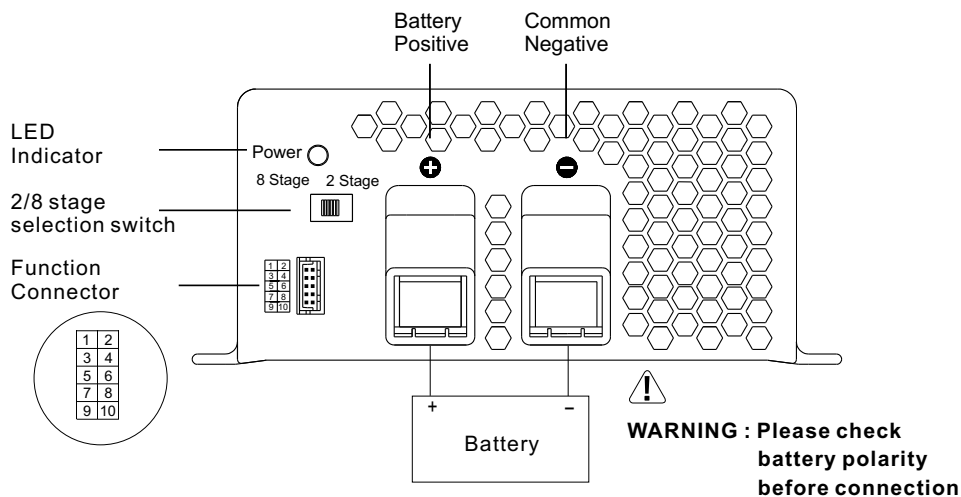

Figure 1.2 Back Panel

Assembly Guidelines:

1. The charger should be turned OFF prior to battery connection. Suitable wire gauge battery polarity before making the battery connection. Positive terminal of the charger must be connected to "+" of the battery and negative terminal to "-" of the battery. Also, make sure the positive and negative terminals of the charger are not accidentally shorted together.
2. After connecting the output cables, flick the ON/OFF (0/-) switch to the ON (-) position. The indicator light on the switch will turn ON.

Notes on Operation:

1. Designed for charging lead acid battery.
2. Must be installed in a dry and well ventilated area. It should not be exposed to rain or snow.
3. The cables between charger and battery should be kept as short as possible to prevent excessive line drop. Too much line drop will lead to longer charging period.
4. Please make sure charging voltage and current meets battery specification.
5. Refrain from connecting new and old batteries in series.
6. PB-600 should be in the OFF mode before making battery connection or disconnection.
7. Three years warranty is provided under normal operating conditions. Failure resulting from improper operation will result in cancellation of warranty.

The appliance is not to be used by persons (including children) with reduced physical, sensory or mental capabilities, or lack of experience and knowledge, unless they have been given supervision or instruction concerning use of the appliance by a person responsible for their safety.

Children should be supervised to ensure that they do not play with the appliance.

2. Derating Curves

2.1 Charging current VS Temperature

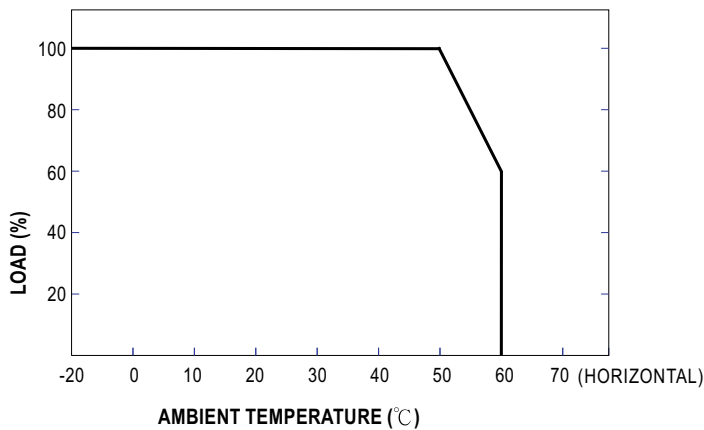

3. Function Description of CN100

Pin No.	Function	Description
1,2	RY13	Relay contact rating(max.) : 30V/1A resistive. ; "Short" when the battery is full, "Open" when the battery is still charging
5,6	RY15	Relay contact rating(max.) : 30V/1A resistive. ; "Short" when the unit is working properly, "Open" when the unit stop charging
7,8	GND / RTH	Temperature sensor comes along with the charger can be connected to the unit to allow temperature compensation of the charging voltage If the temperature sensor is not used, the charger still works normally.
9,10	RC- / RC+	Turn the output on and off by electrical or dry contact between pin 10 (RC+) and pin 9(RC-) Open : Normal work , Short : Stop charging

4. LED Indication

Color of LED	Orange	Green	Red
Battery status	Charging	Battery full	Fail

Types of failure: ① Battery disconnected ② Damaged battery ③ Reverse polarity
④ Incorrect battery voltage (e.g. PB-600-12 connected to 24V battery)
⑤ Activation of protection function (e.g. OTP, OVP, and Short)

5. Explanation of Operation Logic (Charging stages):

8 stages charging differ from 2 stages with the addition of pulse, soft start, analysis, recond, float, and maintain stages. 2 stages provide simple and quick charging. On the other hand, 8 stages will allow charging to maximum capacity. User can select between 2 or 8 stages depending on actual requirement.

5.1 "2" stage charging (Selection switch to "2" stage)

During initial charge (stage 1), charger will provide maximum current to the battery.

The built-in fan will also turn ON. As the battery starts to get full, charging current will gradually decrease (stage 2). When charging current decrease to less than 10% of max. LED indicator will turn Green indicating a full charge.

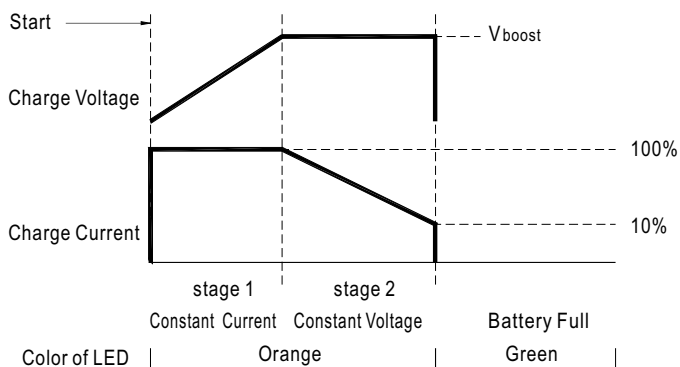

State	PB-600-12	PB-600-24	PB-600-48
V _{boost}	14.4V	28.8V	57.6V
Constant Current	40A	21A	10.5A

Figure 5.1 2 Stage Charging Curve

5.2 "8" stage charging (Selection switch to "8" stage)

Advantage of pulse stage: Use pulse current to revive aged battery.

Advantage of recond stage: Allow full charge of battery.

Advantage of Float and Maintain stage: After LED turns green, maintenance charge is provided so the battery is always in a full state. User will have access to a full battery whenever it is disconnected from the charger.

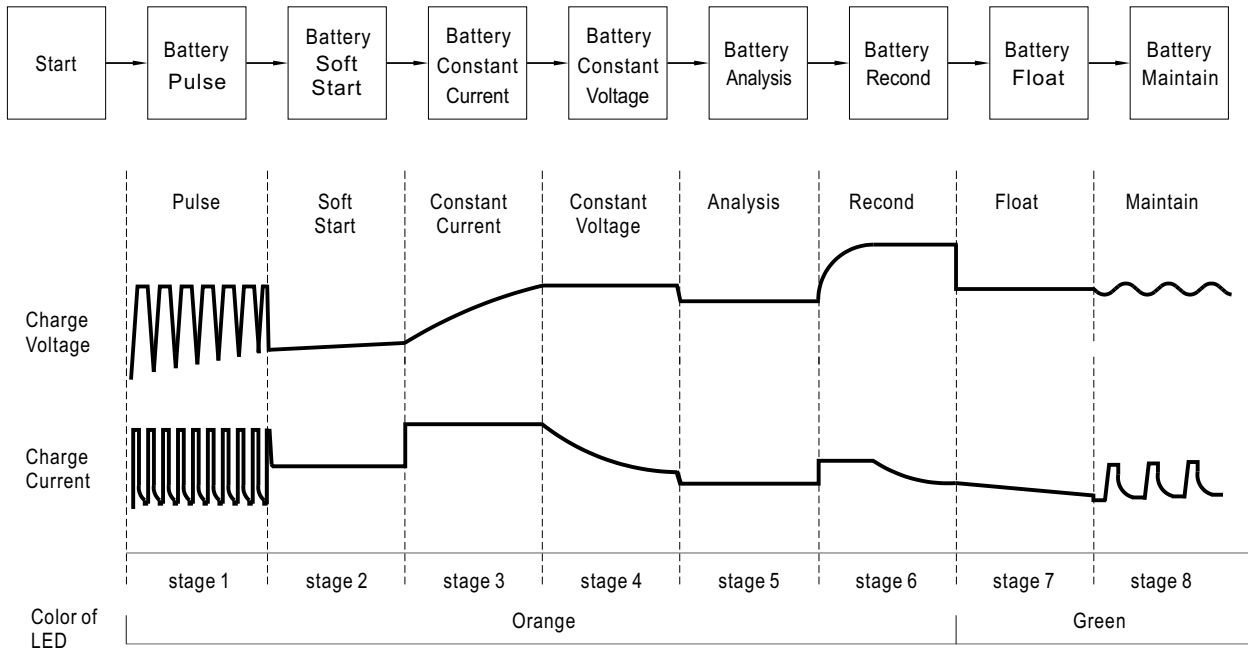

Figure 5.2 8 Stage Charging Curve

6. Function description

6.1 Remote Control

The charger can be turned ON/OFF by using the "Remote Control" function.

Between RC+(pin10) and RC-(pin9)	Charger
SW Open	ON
SW Short	OFF

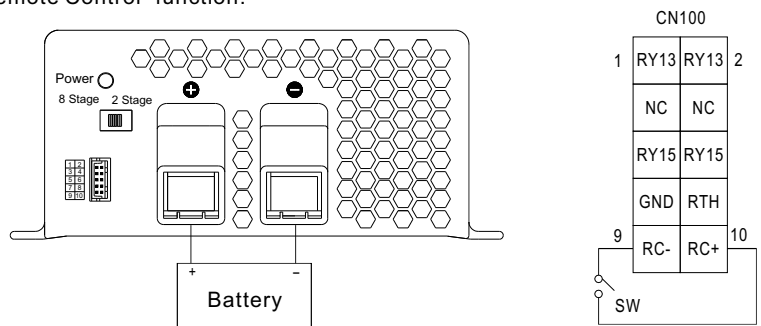

6.2 2 or 8 stage Charging mode Select

The charger features user selectable 2 or 8 stage charging. The charging profile is selected by moving the slide switch on the back panel.

Switch	Charging mode
Turn right	2 stage charging
Turn left	8 stage charging

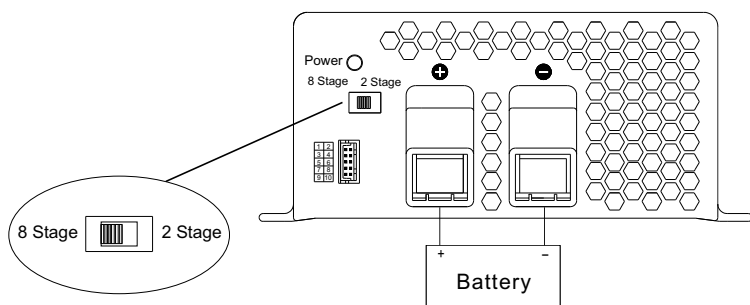

6.3 Charger OK Relay(RY15)

Charger	Between pin5 and pin6
Normal work	ON (Short)
Failure or the protection function is activating	OFF(Open)

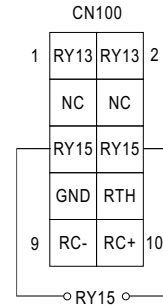

6.4 Output OK Relay(RY13)

1.Bank OK (RY13)

Bank	Between pin1 and pin2	Color of LED
Battery Full	ON (Short)	Green
Charging	OFF(Open)	Orange

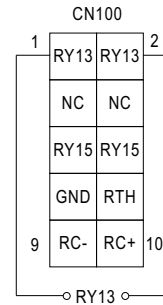

6.5 Temperature Compensation

Temperature sensor comes along with the charger can be connected to the unit to allow temperature compensation of the charging voltage. **If the temperature sensor is not used, the charger still works normally.**

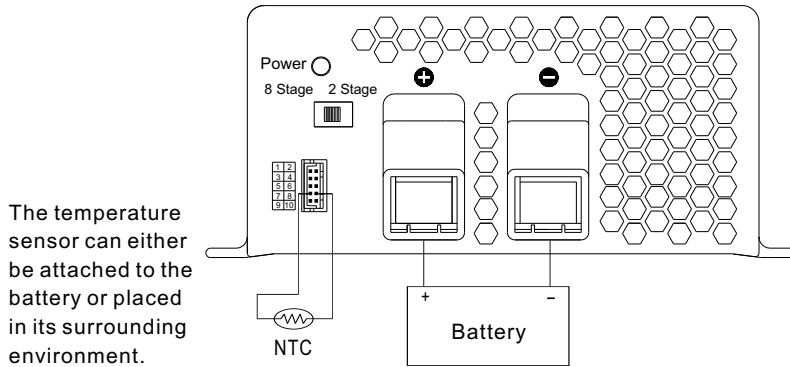

7.Wiring for battery

Select suitable wire gauge based on rated charging current. Refer to the following table for minimum wire gauge. We highly recommend using RED wire for + connection and BLACK wire for - connection:

AWG	CROSS SECTION(mm ²)	Max. Current(A) UL1015(600V 105°C)
14	2.1	12
12	3.3	22
10	5.3	35
7	10	46
6	16	60
4	25	80

8.Suggested battery capacity

Model	Battery capacity
PB-600-12	135-400AH
PB-600-24	70-210AH
PB-600-48	35-105AH

Note:1. Using battery capacity larger than the suggested value will not lead to damage of battery. The only drawback is it may take longer to fully charge the battery.

2. If you're unsure about max allowable charging current of the battery, please refer to the battery's technical specification or consult its manufacturer.

9.Suggested the number of cells

Model	Battery capacity	Number
PB-600-12	100AH	1~4
PB-600-24	80AH	1~3
PB-600-48	46AH	1~2

10.Series and parallel connection of batteries

1.Batteries in series

Voltage can be doubled when 2 batteries are connected in series. However, the capacity (AH) will remain the same.
For example, 2 x 12V 100AH batteries connected in series = 24V 100AH.

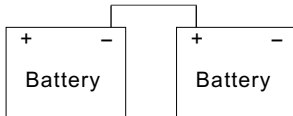

2.Batteries in parallel When 2 batteries are connected in parallel, voltage remains the same and the capacity(AH)doubles.
For example, 2 x 12V 100AH batteries connected in parallel = 12V 200AH.

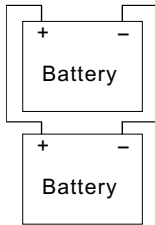

11.Suggested the power cord

Intended use of power unit	Flexible cord type	Maximum length, feet(m)
A. Desk, countertop, rack mounted, or the like	SP-2, SPE-2, SPT-2,SV,SVE,SVT	10 (3)
B. Floor mounted, stationary, or the like	S, SE, SO, SP-3, SPT-3, ST, STO, SJ, SJE, SJO, SJT, SJTO	Not specified

Note : The proper detachable power supply cord type should be selected as table below and shall be minimum No. 18 AWG/3C, provided with a molded on, grounding type attachment plug with 15A, 125V (NEMA 5-15P) or 15A, 250V (NEMA 6-15P) configuration and terminated in molded-on connector which mates with the appliance inlet, minimum 1.8m and maximum length as noted in table below.

12.Failure correction notes

Status	Possible Reasons	Ways to Eliminate
Unable to charge the battery	ON/OFF switch in the OFF position	Switch to the ON position
	Battery reverse polarity	Reconnect using correct polarity
	Battery with higher voltage is connected	Use battery with the correct voltage
	Input AC voltage is too low	Make sure input source is between 90~264VAC
LED indicator does not turn Green after a long charging period	Battery exceed lifespan or damaged	Replace with a new battery
	Output cables are too thin	Replace with suitable wire gauge

If you are not able to clear the failure condition, please contact Mean Well or any of our distributors for repair service.

WARNING : This is a class A product. In a domestic environment this product may cause radio interference in which case the user may be required to take adequate measures.